

PVC Drukreduceerventiel DHV 718

0,5 tot 10 bar, afdichting EPDM membraan

Nominal size DN 8–50

Nominal size 3/8"–2"

Nominal pressure PN 10 bar



Features

- pressure setting range 0.5 to 10 bar
- diaphragm controlled pressure relief valve
- simple design, reliable function
- particularly suitable for oscillating pumps
- constant, frictionless and low vibration control behavior
- high reproducibility of the set pressure
- simple pressure setting possible at any time, even during operation

Additional options on request

- silicone free
- pressure presetting
- sealed
- NSF certification



PVC Drukreduceerventiel DHV 718

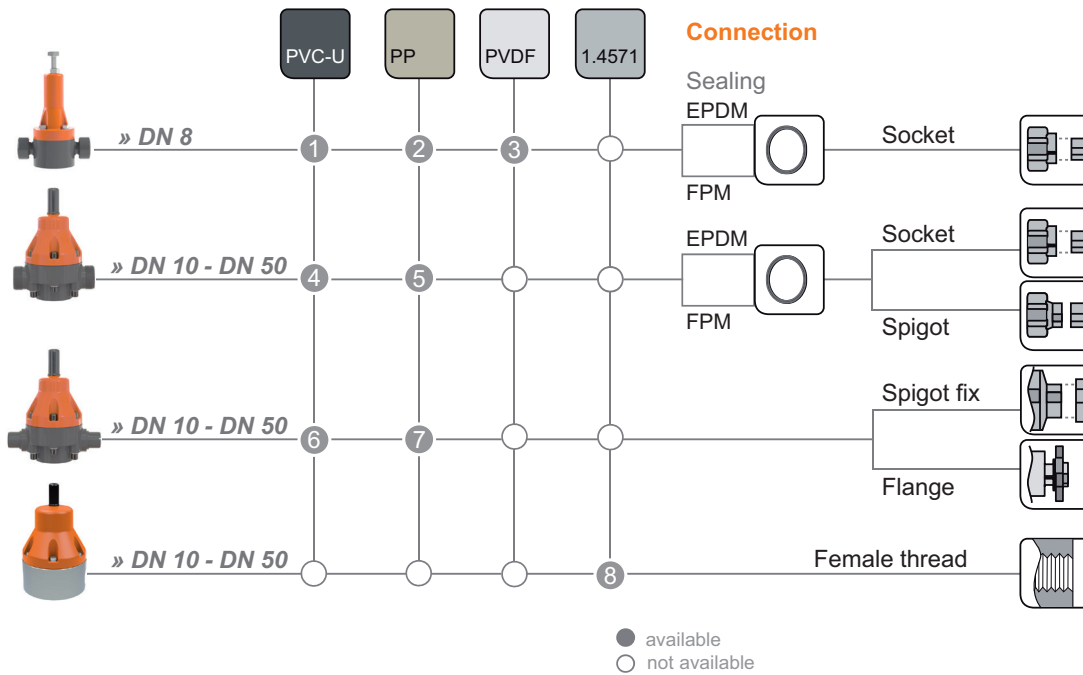

Diaphragm: PTFE (EPDM)

Options: pressure settings in 0.5 bar steps

On demand: sealing
cleaning (free of surface disturbing substances)

Pressure setting range:
0.5–10 bar



Basic Nominal Sizes:

DN 8	DN 10	DN 15	DN 20	DN 25	DN 32	DN 40	DN 50	DN 65	DN 80	DN 100	DN 125	DN 150	DN 200	DN 250	DN 300	DN 350	DN 400
------	-------	-------	-------	-------	-------	-------	-------	-------	-------	--------	--------	--------	--------	--------	--------	--------	--------

Connection Material (process connection)

<p>1 PVC-U socket DIN DN 8.</p> <p>2 PP socket DIN DN 8.</p> <p>3 PVDF socket DIN DN 8.</p> <p>4 PVC-U socket DIN, ANSI, BS, JIS female thread Rp, NPT 1.4571 male thread R female thread Rp DN 10–50. PE100 spigot DIN (95 mm) DN 15–50.</p>	<p>5 PP socket DIN female thread Rp DN 10–50. PP spigot (IR) DN 15–50.</p> <p>6 PVC-U spigot fix DN 10–50. PP/St. flange DIN, ANSI DN 15–50. GFK flange DIN DN 15–50.</p> <p>7 PP spigot fix DN* 10–50. PP/St. flange DIN, ANSI DN 15–50. GFK flange DIN DN 15–50.</p> <p>8 1.4571 female thread Rp female thread NPT DN 10–50. * only for socket welding.</p>
--	---

PVC Drukreduceerventiel DHV 718

Use

- chemical plant engineering
- industrial plant engineering
- water treatment
- Electroplating plants

Application

- The pressure relief valve which is directly controlled by the medium, is used in technical processing plants for keeping preset working pressures constant on the primary side.
- The pressure relief valve can also be used as an overflow valve to prevent pressure peaks. In this case, the pressure relief valve is fitted in a bypass line.
- Pressure relief valves are not safety valves in the sense of the pressure vessel directive.

Valve function

- When the valve is closed in the position of rest, the diaphragm under the valve seat is only impinged by the low secondary pressure. Any rise in working or primary pressure lifts the diaphragm against the spring force. The valve opens and the pressure decreases.

Valve setting

- can be adjusted easily across the entire pressure range
- can be secured against unauthorized opening by sealing

Flow medium

- Neutral and aggressive fluids or fluids containing solid particles, provided that the valve components coming into contact with the fluids are resistant at the operating temperature in accordance with the ASV resistance guide.

Note

For nitric or sulphuric acid, please contact us and indicate the exact operating conditions!

Flow direction

- always in the direction of the arrow, see graphics „Sectional drawing“

ASV resistance guide

www.asv-stuebbe.de/pdf_resistance/300051.pdf

Process temperature

- See graphics „Pressure/temperature diagram“

Process pressure

- See graphics „Pressure/temperature diagram“

Nominal pressure (H₂O, 20 °C)

- PN 10 bar

Size

- DN 8–50

Pressure setting range

- 0.5–10 bar

Working pressure

- is the set pressure plus flow dependent pressure increase (see characteristic curves): 0.5–10 bar

Opening pressure

- DN 8: 0.5 bar
- DN 10–50: 0.3 bar

Hysteresis

- Difference between opening and closing pressure approx. 0.3 bar

Note

- When the valve is in the position of rest, the counter-pressure (secondary pressure) may be approx. 4 times higher than the set pressure pE, the valve remains closed.
- Return flow is excluded by the DHV718

PVC Drukreduceerventiel DHV 718

Actuation

- medium controlled

Device connection

- see graphics „Pictograph pressure relief valve DHV 718“

Material with medium contact

Housing:

- DN 8: PVC-U, PP or PVDF
- DN 10–50: PVC-U, PP or stainless steel A4 (1.4571)

Diaphragm:

- PTFE
(EPDM diaphragm, PTFE-coated on the medium side)

Sealing:

- FPM, EPDM

Note

Please observe that the material PTFE is classified as resistant to several media, however, is not diffusion-tight, in particular, if used as film such as, for example, the ASV diaphragms.

For borderline cases (Azotic acid or Sulfuric acid), please contact us.

Material without medium contact

Bonnet

- PP, glass fiber reinforced

Screws:

- stainless steel A4 (1.4301)

Mounting position

- as required

Fastening

- via threaded inserts (metal inserts) in the valve body

Color

Housing:

- PVC-U, gray, RAL 7011
- PP, gray, RAL 7032
- PVDF, opaque, yellowish-white
- stainless steel, unpainted

bonnet:

- orange, RAL 2004

PVC Drukreduceerventiel DHV 718

Pressure/temperature diagram

The pressure/temperature limits of the materials are valid for the stated nominal pressures and a service life of 25 years. These values are guide values for flow medium types which do not negatively impact the physical and chemical characteristics of the valve material. It may be necessary to take diminution factors into consideration. The operating life of the wear parts depends on the conditions of use.

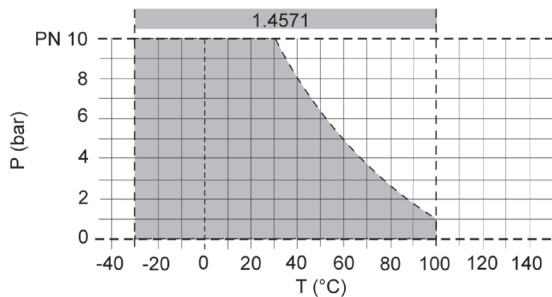
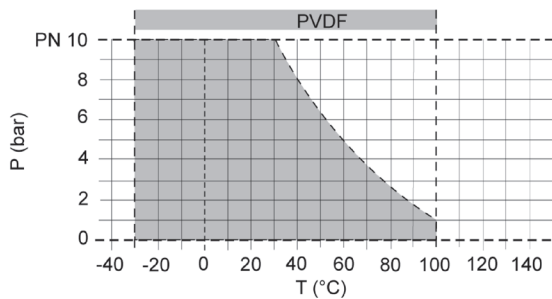
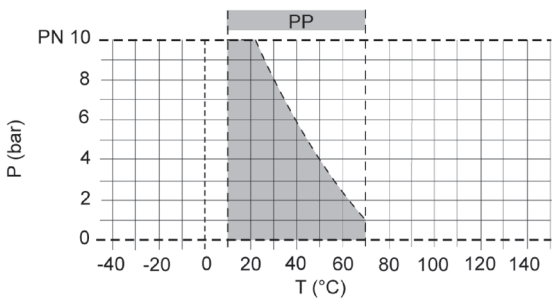
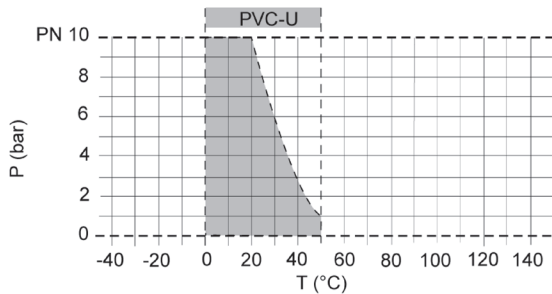

Description	
P	Operating pressure
T	Temperature

PVC Drukreduceerventiel DHV 718

Operating behavior

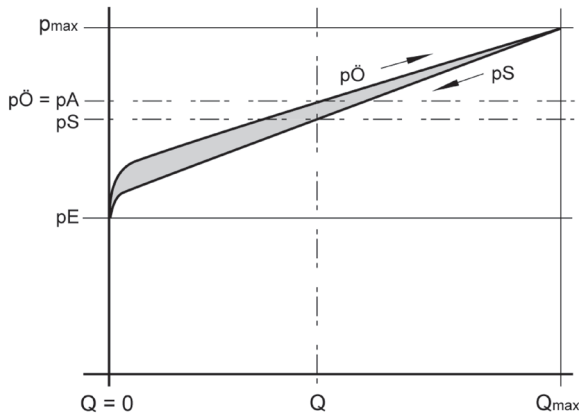

	Description
p_{max}	Maximum pressure
p_A	Working pressure
p_E	Set pressure
$p_A - p_E$	Flow-dependent pressure increase
p_O	Opening pressure
p_S	Closing pressure
$p_O - p_S$	Hysteresis
Q	Flow
Q_{max}	Maximum flow

Characteristic curve, design example

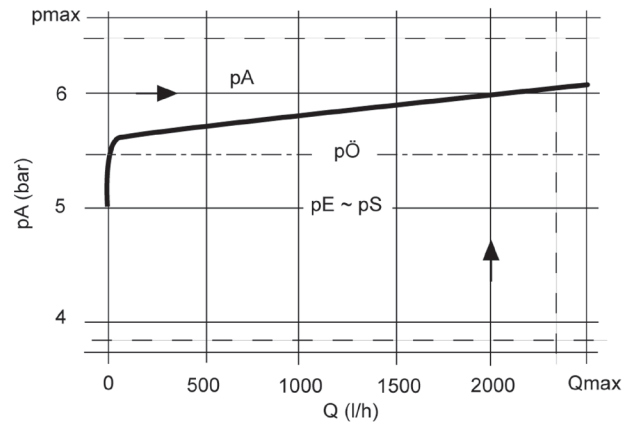

	Description
p_{max}	Maximum pressure
p_A	Working pressure
p_E	Set pressure
p_O	Opening pressure
p_S	Closing pressure
Q	Flow
Q_{max}	Maximum flow

The valve is set tight at 5 bar.

A flow of approx. 2000 l/h is reached at a pressure increase of 1 bar.

According to the curve, this results in the following values:

Set pressure p_E : 5 bar

working pressure p_A : 6 bar

opening pressure p_O : 5.5 bar

closing pressure p_S : 5 bar

PVC Drukreduceerventiel DMV 712R

Characteristic curve pressure setting range

DN 8

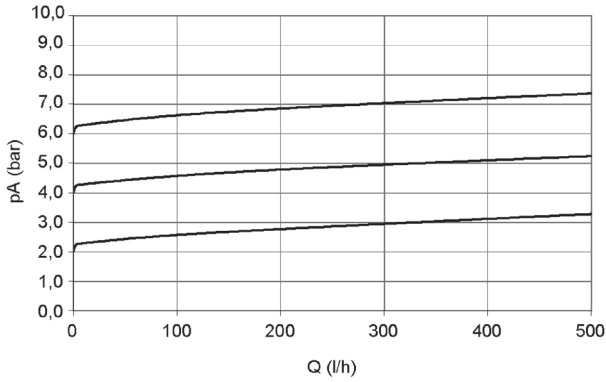

DN 20

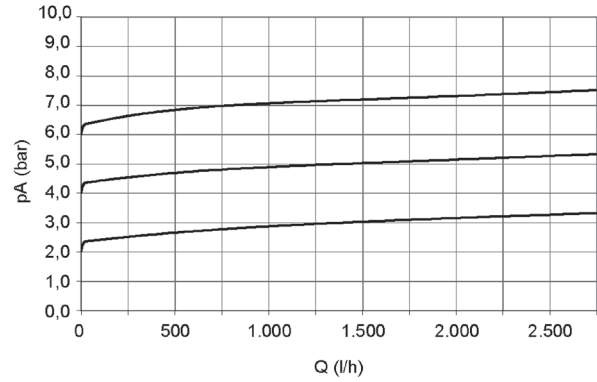

DN 10

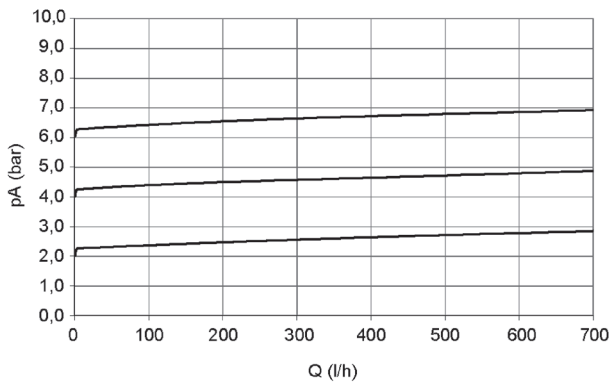

DN 25

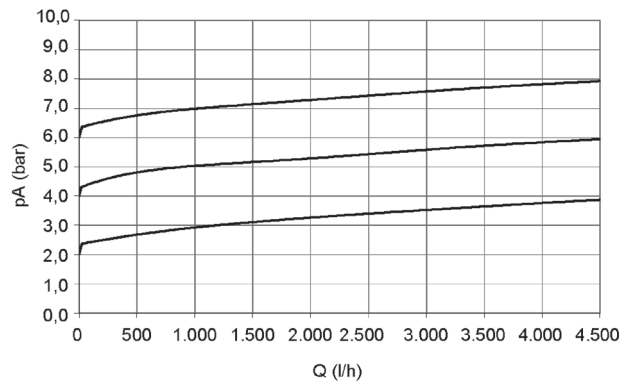

DN 15

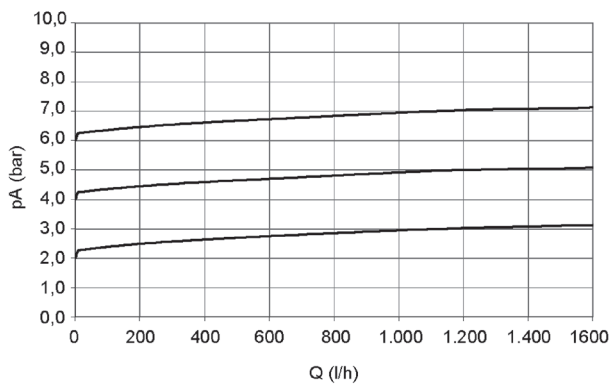

DN 32

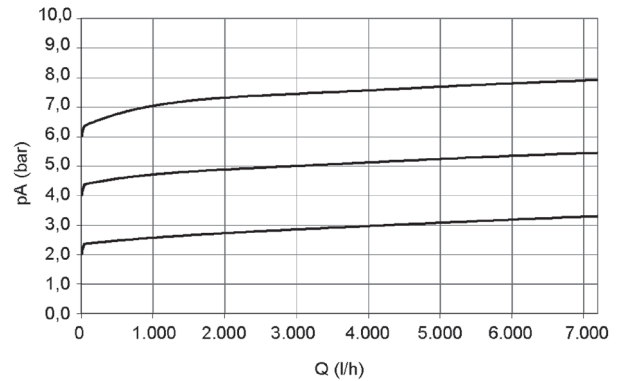

PVC Drukreduceerventiel DHV 718

DN 40

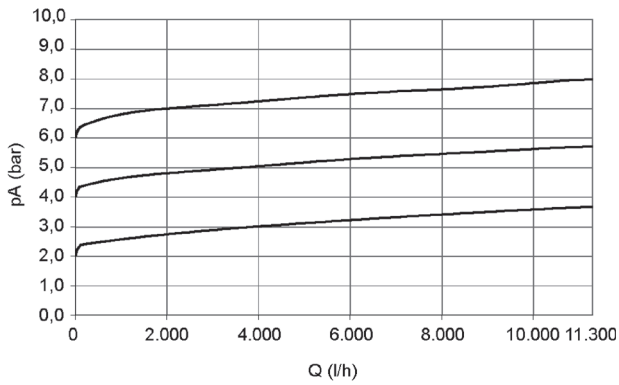

DN 50

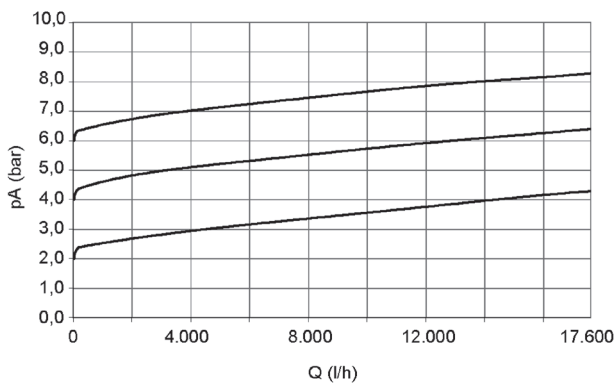

	Description
pA	Working pressure
Q	Flow

Pressure loss curve (standard values for H₂O, 20 °C)

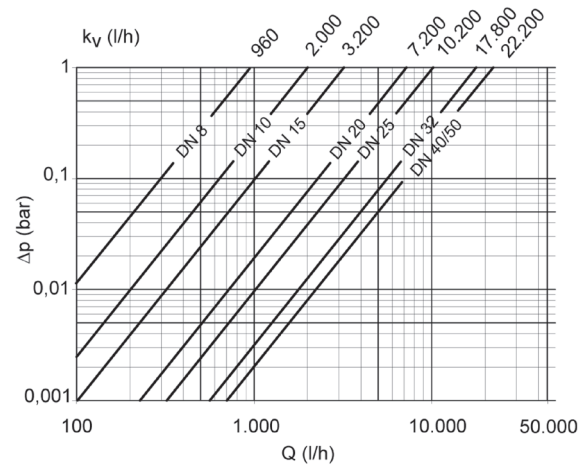

	Description
Δp	Pressure loss
Q	Flow

Pressure loss and k_v value

The diagram shows the pressure loss Δp in relation to the flow Q .

Conversion formulas

$$c_v = k_v \times 0.07$$

$$f_v = k_v \times 0.0585$$

Units:

k_v [l/min]

c_v [gal/min] US

f_v [gal/min] GB

PVC Drukreduceerventiel DHV 718

Applications for pressure relief valves

Example 1: Generation of a constant operating pressure

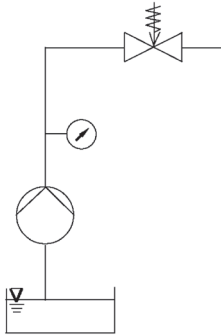

Example 2: Use with high primary pressure

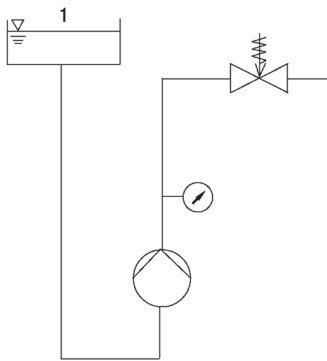

Example 3: Reduction of pressure impacts due to an overflow valve to protect the plant

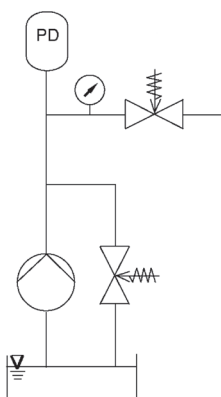

Description

PD	Pulsation damper
----	------------------

PVC Drukreduceerventiel DHV 718

Connection socket

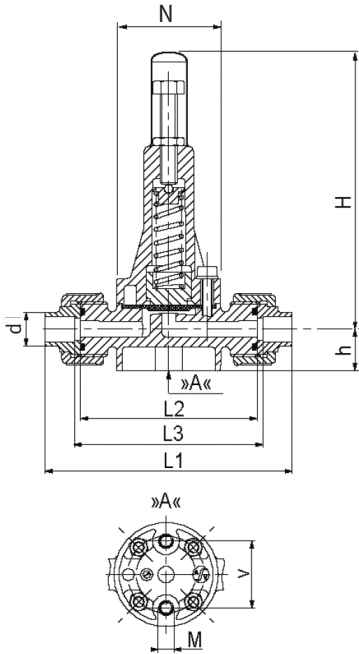

d (mm)	12
DN (mm)	8
DN (inch)	1/4
H	134
h	20
L1	119
L2	85
L3	91
M	M 5
N	50
v	32

Connection, female thread A4 1.4571

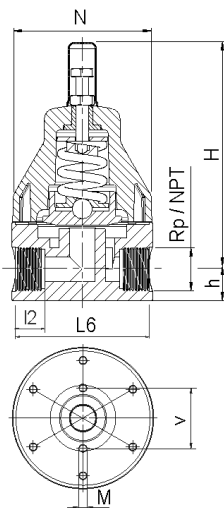

d (mm)	16	20	25	32	40	50	63
DN (mm)	10	15	20	25	32	40	50
DN (inch)	3/8	1/2	3/4	1	1 1/4	1 1/2	2
h	1.4571	16	16	24	24	24,5	30
H		151	151	175	175	220	230,5
l2		16	18	20	22	25	25
L6		79	79	103	103	142	140
M		M6	M6	M6	M6	M8	M8
N		81,5	81,5	108	108	148	148
NPT *		3/8	1/2	3/4	1	1 1/4	1 1/2
Rp*		3/8	1/2	3/4	1	1 1/4	1 1/2
V		40	40	46	46	65	65

all dimensions in mm / * dimensions in inch

PVC Drukreduceerventiel DHV 718

Connection Spigot/Socket

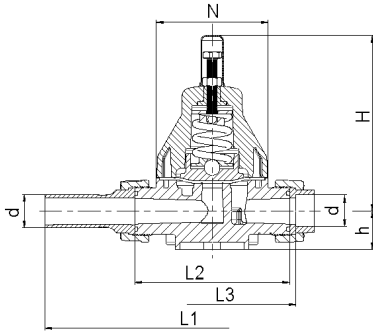

Connection, spigot, fixed/flange

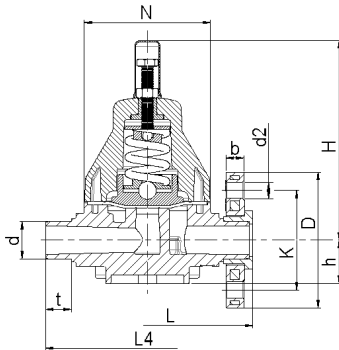

Connection male thread/ female thread

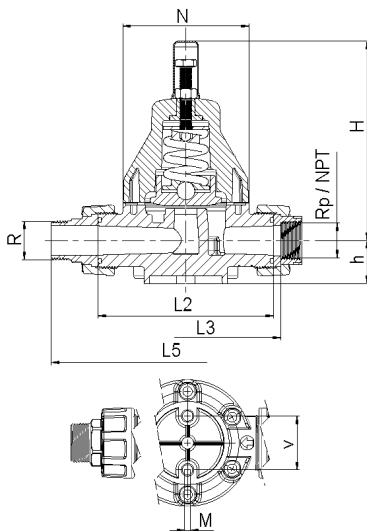

d (mm)		16	20	25	32	40	50	63	
DN (mm)		10	15	20	25	32	40	50	
DN (inch)		3/8	1/2	3/4	1	1 1/4	1 1/2	2	
Valve body	Insert/flange								
b	GFR flange DIN	-	12.2	14	15	17	17	18.5	
	PP steel flange DIN	-	13	14.5	15.5	17.5	17.5	19	
	PP steel flange ANSI	-	12	12	16	16	18	18	
d2	GFR flange DIN	-	14	14	14	18	18	18	
	PP steel flange DIN	-	14	14	14	18	18	18	
	PP steel flange ANSI	-	16	16	16	16	16	20	
D	GFR flange DIN	-	96.5	106	115	142	152	168	
	PP steel flange DIN	-	96	106	116	141	151	166	
	PP steel flange ANSI	-	95	105	113	130	133	160	
G*		3/4	1	1 1/4	1 1/2	2	2 1/4	2 3/4	
h	PVC-U, PP	25	25	37	37	57	57	57	
H	PVC-U, PP	151	151	170	170	219	219	219	
K	GFR flange DIN	-	65	75	85	100	110	125	
	PP steel flange DIN	-	60	70	80	89	98	121	
	PP steel flange ANSI	-	65	75	85	100	110	125	
L	PVC-U	-	150	180	180	230	231.4	250	
	PP	-	150	180	180	230	230	250.4	
L1	PVC-U	-	-	340	340	405	433	453	
	PP	-	228	264	270	331	338	343	
L2	PP, PVC-U	120	120	150	150	205	205	205	
L3	PVC-U	PVC-U DIN socket, PVC-U ANSI, BS	126	126	156	156	211	211	211
		PVC-U socket JIS	132	128	160	159	211	211	213
		PVC-U female thread Rp	126	127.6	158	162.6	221	226	235.6
		PVC-U female thread NPT	126	124	162	162	211	217	217
	PP	Female thread Rp 1.4571	130	130	161	164	221	223	223
		PP socket DIN	128	126	156	156	211	211	211
		PP female thread Rp	126	126	157	156.6	212	213	214
L4	PVC-U, PP	144	144	174	174	224	224	244	
L5	PVC-U	182	188	222	230	297	301	315	
M		M6	M6	M6	M6	M8	M8	M8	
N		81.5	81.5	108	108	148	148	148	
NPT*		3/8	1/2	3/4	1	1 1/4	1 1/2	2	
Rp*		3/8	1/2	3/4	1	1 1/4	1 1/2	2	
t		14	16	19	22	26	30	38	
V		40	40	46	46	65	65	65	

all dimensions in mm / * dimensions in inch

PVC Drukreduceerventiel DHV 718

Sectional drawing

DN 8

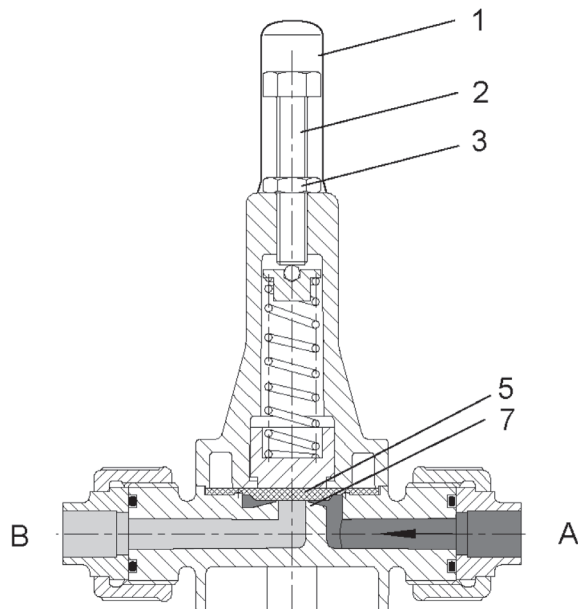

Description	
A	Primary side
B	Secondary side
1	Protection cap
2	Adjustment screw
3	Counter nut
5	Diaphragm
7	Valve seat

DN 10-15

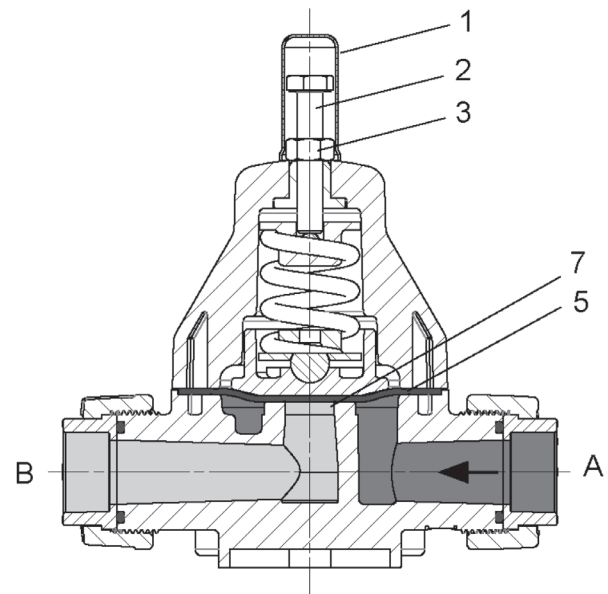

Description	
A	Primary side
B	Secondary side
1	Protection cap
2	Adjustment screw
3	Counter nut
5	Diaphragm
7	Valve seat

PVC Drukreduceerventiel DHV 718

Components

DN 8, Housing: PVC-U, PP, PVDF

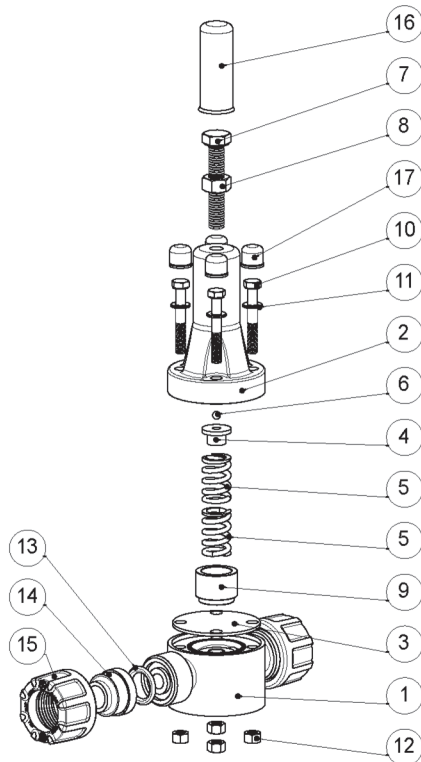

Quantity	Description
1	Housing, complete
2	Bonnet
3	Diaphragm
4	Pressure plate
5	Pressure spring
6	Steel ball
7	Hexagon screw
8	Hexagon nut
9	Spring plate
10	Cylinder screw
11	Washer
12	Hexagon nut
13	O-ring
14	Union end
15	Union nut
16	Protection cap
17	Protection cap

DN 10-50, Housing: PVC-U, PP

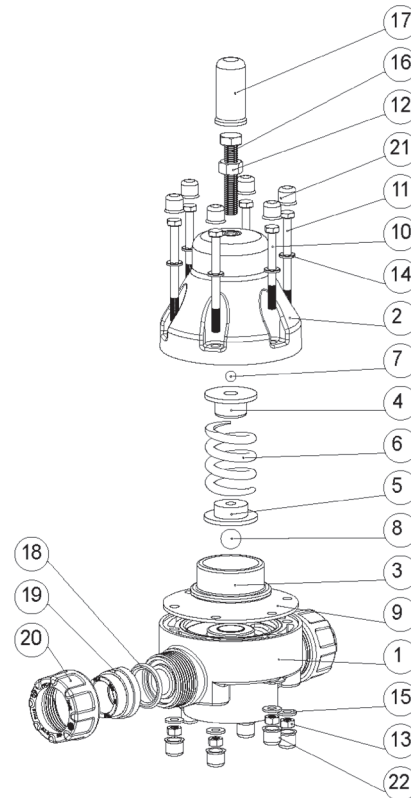

Quantity	Description
1	Housing, complete
2	Bonnet
3	diaphragm disc
4	Pressure plate
5	Spring plate
6	Pressure spring
7	Steel ball
8	Steel ball
9	Diaphragm
10	Hexagon screw
11	Hexagon screw
12	Hexagon nut
13	Hexagon nut
14	Washer
15	Washer
16	Hexagon screw
17	Protection cap
18	O-ring
19	Union end
20	Union nut
21	Protection cap
22	Protection cap

PVC Drukreduceerventiel DHV 718

DN 10–50, Housing: stainless steel A4 (1.4571)

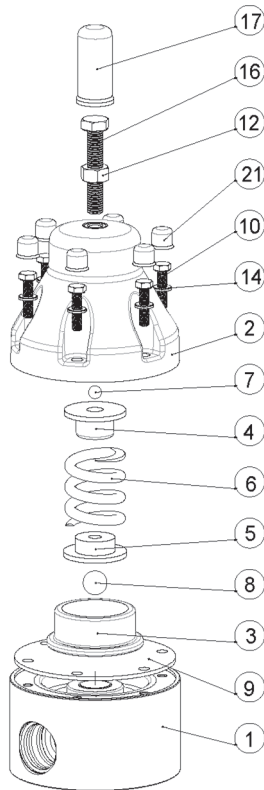

	Quantity	Description
1	1	Housing, complete
2	1	Bonnet
3	1	diaphragm disc
4	1	Pressure plate
5	1	Spring plate
6	1	Pressure spring
7	1	Steel ball
8	1	Steel ball
9	1	Diaphragm
10	4	Hexagon screw
12	1	Hexagon nut
14	6	Washer
16	1	Hexagon screw
17	1	Protection cap
21	6	Protection cap